

(1) Non-interchangeable type

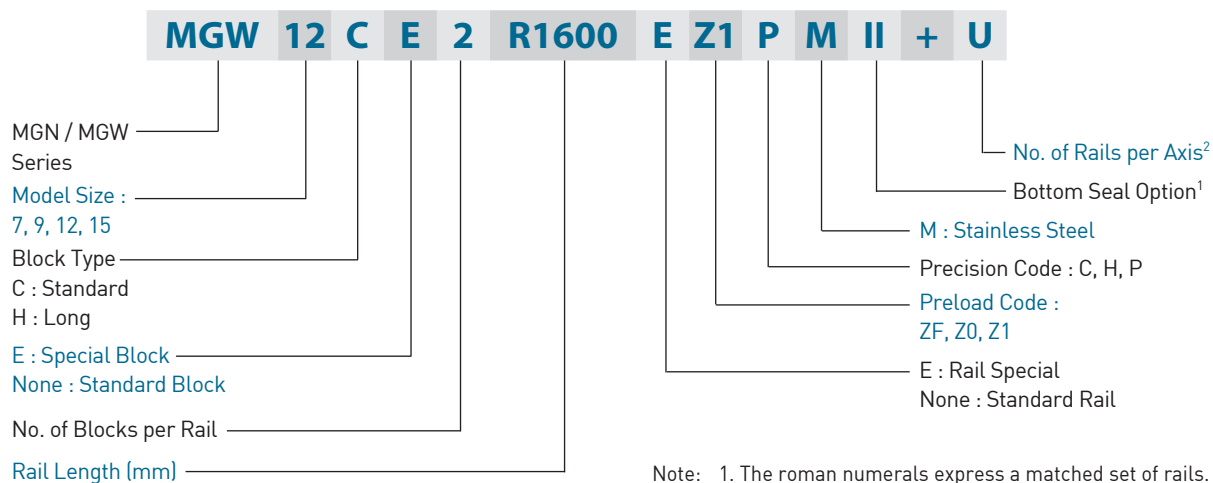

Note: 1. The roman numerals express a matched set of rails.
No symbol indicates single rail in an axis.
2. The bottom seal is available for MGN & MGW 9, 12, 15.

(2) Interchangeable type

○ Interchangeable Block

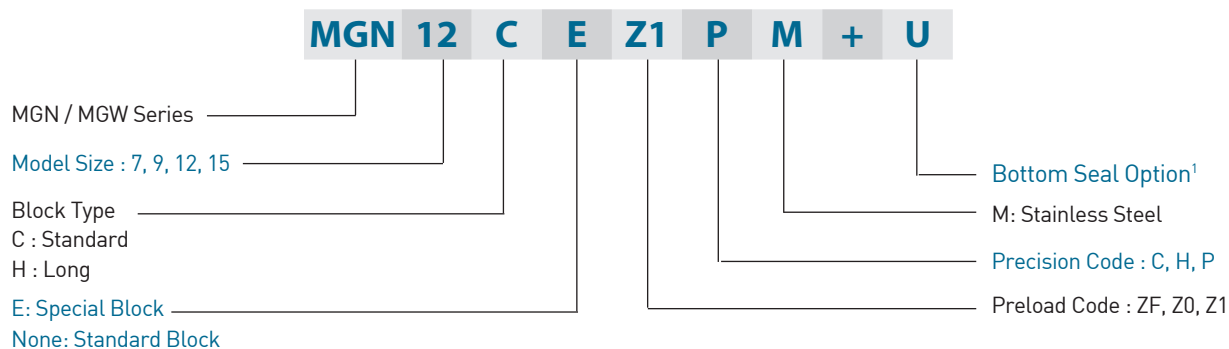

○ Interchangeable Rail

