

## I. LMSP Operation Note

### 1. Fixture mechanism design

- a. Fixture surface flatness must be less than  $5\mu\text{m}/300\text{mm}$ , otherwise the forcer may be bent thus cause abnormal function of air bearing or servo resonance.

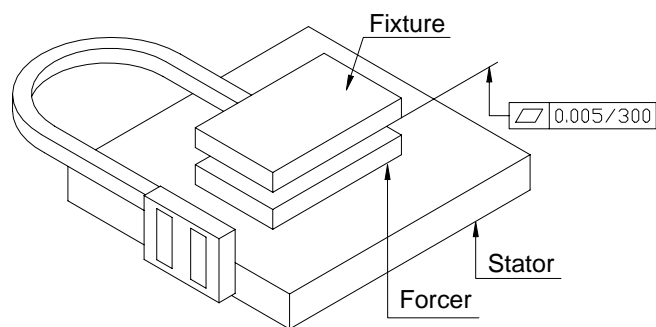

- b. The foundation for the stator, its surface flatness must be less than  $5\mu\text{m}/300\text{mm}$ , otherwise will cause stator to be bent also.

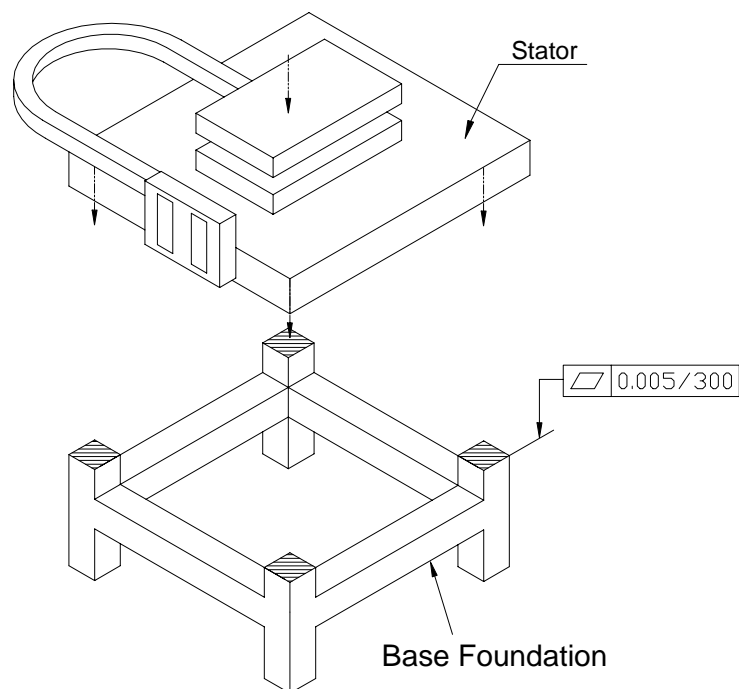

- c. Please follow the order numbered steps to fasten the screw in many cycles to make sure the tight balanced junction between your fixture and the forcer. Make the center of payload fall in the center of forcer and the lower the better to lessen motor control error.

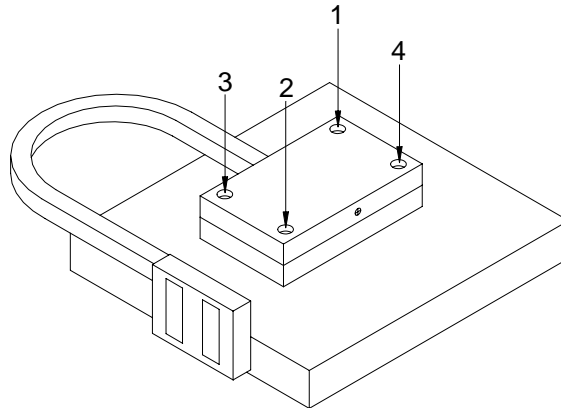

- d. In the vicinity of the forcer avoid placing any strong magnetic material to effect the normal operation of the forcer.

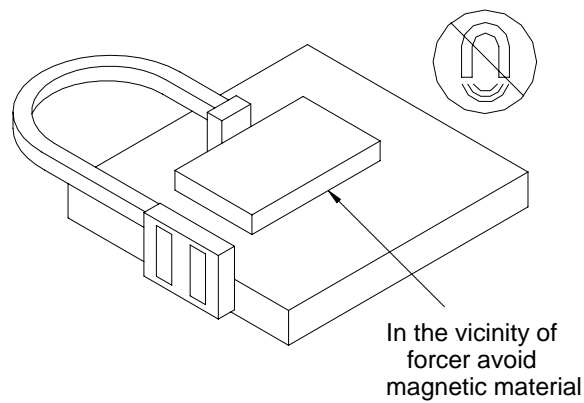

- e. payload's parallelism adjust avoid using point contact, use plane contact.

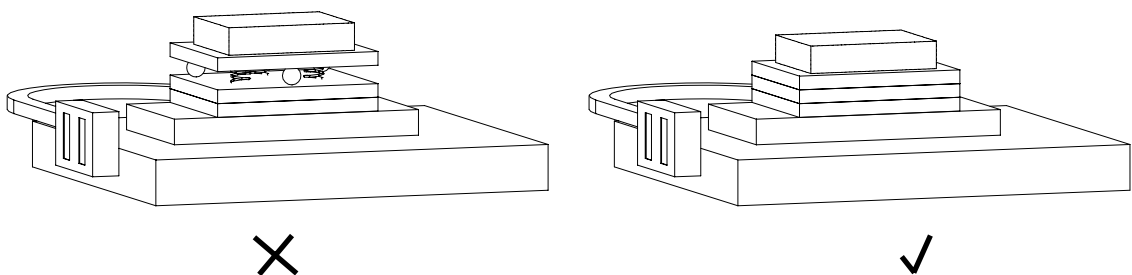

## 2. Suppressed air supply:

- a. It needs filter equipment, to filter out water and other particles to provide clean air, the pressure is between 3 and 4 bars.
- b. The air gap between forcer and stator is 10-15 $\mu$ m. If you the pressure is too small (<3 bar), it will scratch the surface of the stator I, if the pressure is too large (>4 bar), the rigidity will become small and it is easy to get drooping effect thus cause vibration.

## 3. Driver

- a. The cabinet of the driver, beware of its ventilations and heat dissipation check the location of its fan. the allocation distances suggested are as follows.

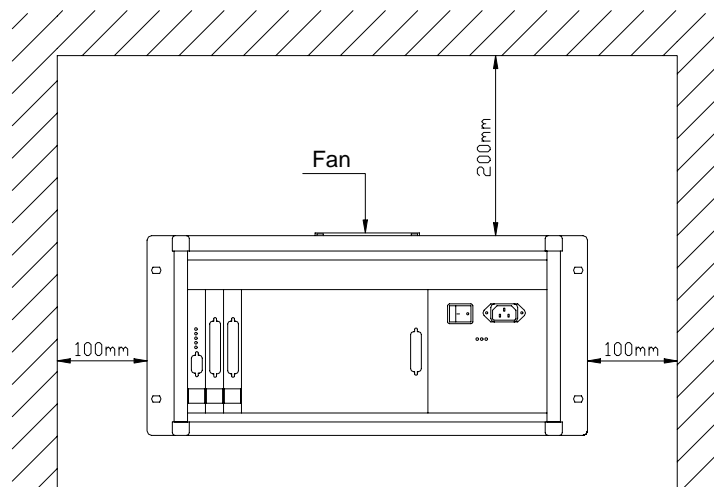

- b. Make sure the LMACK20H motor line, LMACE20C encoder line, RS232 signal line LMACR20A, have been fasten up tightly to avoid bad connections.
- c. When the power is on, never to plug in or take out any control line ,especially the RS232, it may cause short circuit, electric shock or system failure.

(The panel of the driver is as follows.)

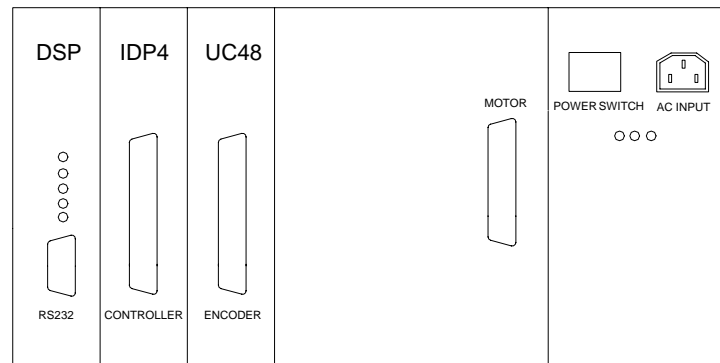

- d. The DIP switch on the PU2 amplifiers should be set up correctly and be careful of the specification of the fuses. The PCB are numbered, the DIP switch and fuses locations on the board have been shown in the following two figures.
- 4 PU2 amplifier PCB boards:

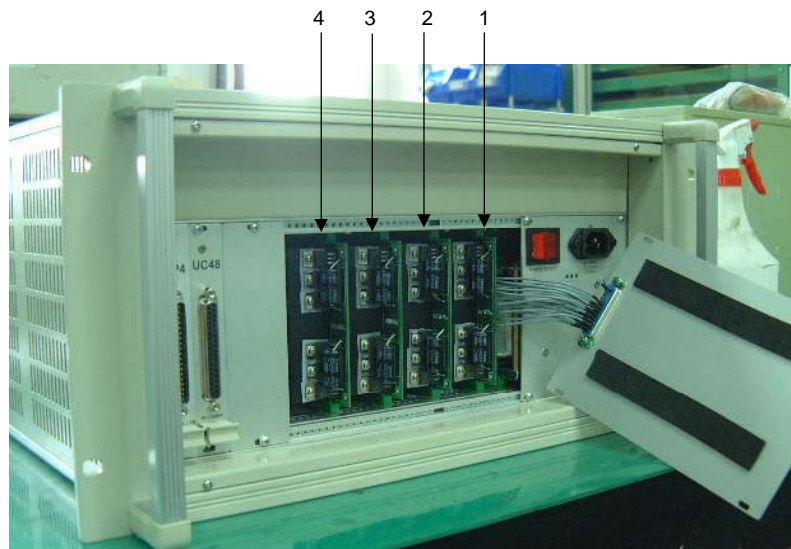

- DIP switches and fuses on the PCB:  
The specification of the fuse is T6.3A/AC250V time lag type.

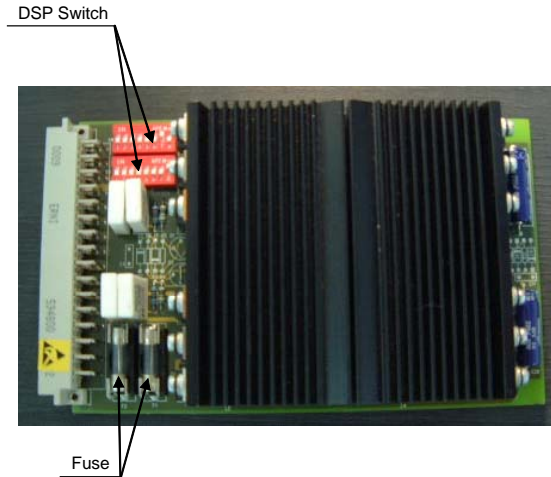

- The numbered PU2, PCB , the DIP switches have been set as follows:  
There are two DIP switches placed one is up and the other is down in parallel on each PU2 board.

The toggle is in upper position when it is on.

