

REVISIONS				
ZONE	REV.	DESCRIPTION	DATE	APPROVED
C7	A	Added Sheave Guard	11/2/2009	B.B.
AB-7	A	Inserted Motor Information	11/2/2009	B.B.

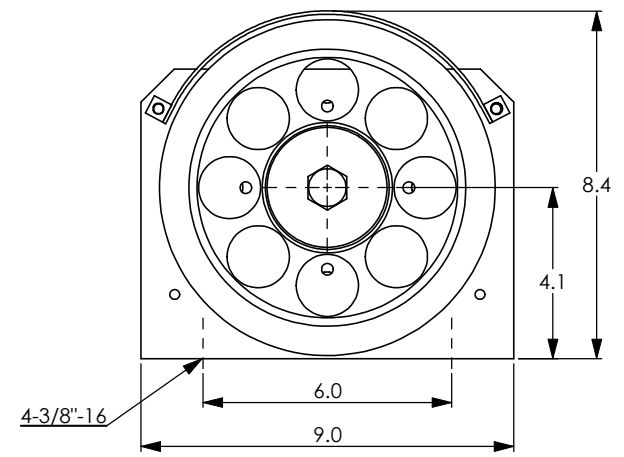
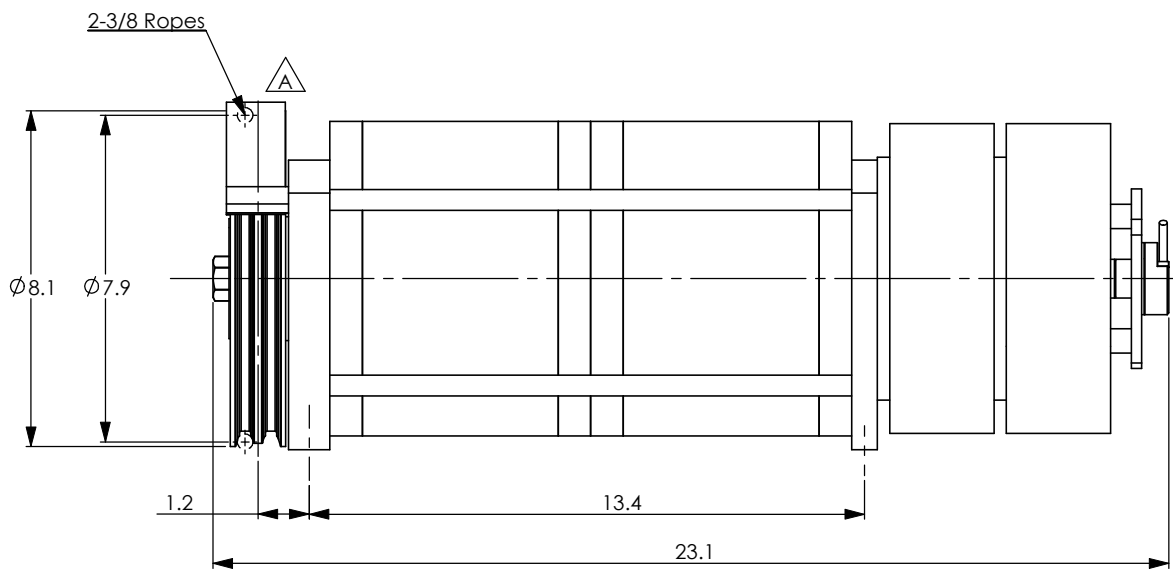

Specifications	
Duty Load	1400lb
Max. Speed	72ft/min
Sheave Shaft Load	5,510lb
Roping	2:1
Wrap	Single
Sheave Diameter	7.874in
Ropes	2 x 3/8"
Number of Motor Poles	22
Max. Voltage	230V
Max. Current	9A
Brake Torque	140%
Brake Voltage	100VDC
Brake Current	0.9A

BREAK SHARP EDGES UNLESS OTHERWISE SPECIFIED									
ROUGH M/C		FIT M/C		GRD		MATERIAL		FINISH	
6.3 a	▽	1.6 a	▽▽	0.4 a	▽▽▽				
TOLERANCE mm									
UP	6	30	120	300	600	1200	2400		
TO	6	30	120	300	600	1200	2400	OVER	
	± 0.1	± 0.2	± 0.3	± 0.4	± 0.5	± 0.8	± 1.0	± 1.5	

DRAWN	09/11/08	NAME	B.B.	 HIWIN CORPORATION 1400 Madeline Lane, Elgin, IL 60124 TITLE: LAYOUT DRAWING TMR-ELE-02 CUSTOMER: HIWIN
CHECKED				
ENG APPR.				
MFG APPR.				
Q.A.				THIRD ANGLE PROJECTION
SIZE	B	DWG. NO.	C-HIW-08-28	REV A SCALE 1:3 SHEET 1 of 1