

PMLD-A-XX-X-XX

PMLD User's Manual



PMLD-A-XX-X-XX USER's manual (VER 1.1)

Content

1. Installation	34
2. Functions	35
3. LCD Panel Description	36
4. Key Pad description	37
5. Function Mode	38
6. Base Point/Origin(Org)	39
7. Direction (Dir)	41
8. Resolution (Dot)	42
9. Offset setting (Offset)	43
10. Offset calling	45
11. Scale (Scale)	46
12. Radius setting (Rad)	47
13. Gap Tuning (Tune)	48
14. Read Head traveling speed setting (Speed)	51
15. Battery capacity (Bat)	52
16. Software Version (Edit)	53
17. Parameter default	54
18. Dimension	55
19. Appendix	56
20. Version History	60

1. Installation

(1) At installation, the position of read-head is important.

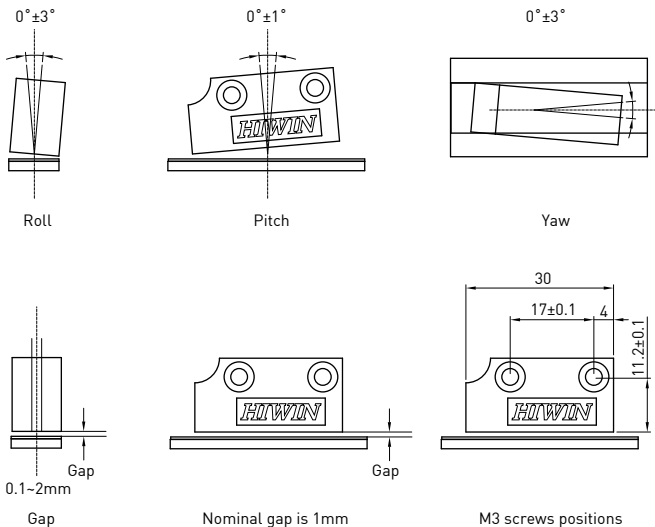

☆☆ [2] Gap Tuning: (Warning)

In order to guarantee the accuracy of system, gap tuning procedure must be done after battery changed or reinstallation of read head. [Reference page: P.17]

2. Functions and Specifications

(1) Functions

1. Switching between ABS and REL. See appendix.
2. Units of measurement: mm/inch/deg
3. Base point (Origin) coordinate setting
(Setting of the coordinate where it stops at the moment.)
4. Counting direction setting (increase/decrease)
5. Resolution setting (decimal point setting)
mm={0.005, 0.01, 0.1, 1}; inch={0.0001, 0.001, 0.01, 0.1};
deg={0.001, 0.01, 0.1, 1}
6. 5 sets of offset settings. See appendix.
7. Programmable scaling factor.
8. Diameter setting for arc measurement. (The smallest radius is 50mm.)
9. Gap adjustment assistant (For better installation.)
10. Rated velocity setting (Maximum speed)
11. Battery condition display
12. Key lock

(2) Specifications

- ◎ LCD 8 digits display
- ◎ Use two 1.5 V AA Type battery (No. 3 battery)
- ◎ Max. gap between read head and tape 2.0mm
- ◎ Operation: 4 keys
- ◎ Temperature for stocking : -5°C ~ +65°C
- ◎ Operation temperature: 0°C ~ +50°C
- ◎ Battery life circa one year (Assumed speed is set to 1.5 m/sec or below)

3. LCD display panel

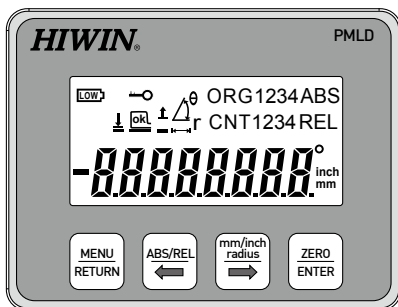

- | | | | |
|---|---------------------------|---|-------------------------------|
| ORG1234 : 5 sets of ABS counter
-see appendix | | : Gap too big | |
| CNT1234 : 5 sets of REL counter
-see appendix | | : Gap too short | |
| | : Degree | | : Blinking (Gap not adjusted) |
| mm : mm | OK : Gap is proper | | |
| inch : inch | ABS : ABS mode | | |
| | : Radius setting | REL : REL (INC) mode | |
| | : Radius value | LOW : Battery low | |
| | : Key locked | | : minus |
| | : Bad flatness | NO SEN : Read head is away from tape | |

4. Key operations

⊙ Normal mode

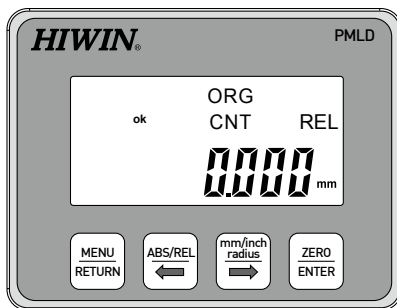

⊙ The meaning of key at the Normal mode:



: Menu



: Switching between ABS/REL mode



: Switching between units (mm/inch/degree)



: Set to zero (only for REL mode)



+



: Lock and unlock the key



+



: ABS mode: switching ORG
: REL mode: switching CNT

5. Function Mode

At normal mode, press MENU to enter function mode.

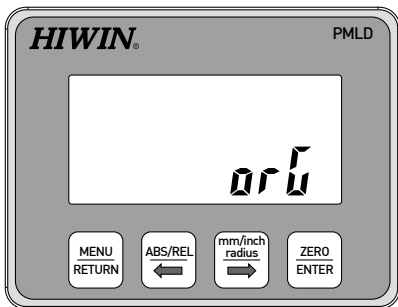

◎ The meaning of key at the Function mode:



: Return to normal mode/Back one page



: Switching between functions
Org > Dir > Dot > Offset > Scale > Rad > Tune > Speed > Bat > Edit > Org



: Switching between functions
Org > Edit > Bat > Speed > Tune > Rad > Scale > Offset > Dot > Dir > Org



: Confirmation key

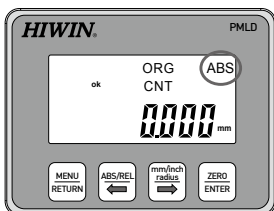

6. Base point (origin) setting (Org)

Function: This is to set the origin coordinate. (It sets the coordinate where it stops at the moment.) User can set the value according to need. It can be zero or non-zero. If it is zero, it is origin. This is only for ABS mode.

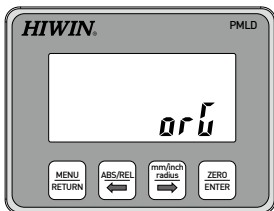

Step 1. If not in ABS mode, press  to switch into ABS mode.



Step 2. Press  once, then press  or  until it shows Org.

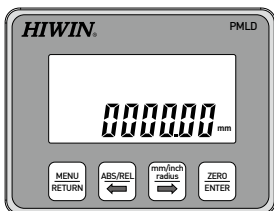

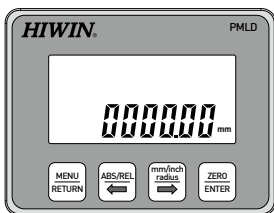

Step 3. Press  to enter setting.



Step 4. Press  to set the sign. Then press

 to switch to next digit. the digit

will flicker. Press to  change the

value, After change is done, press 

to confirm. The display will show the newly

set value. Press  to confirm.

Note: The setting range is $-360^{\circ} \sim +360^{\circ}$ at the angle mode.

Note: If parameter is over the setting range, it will shows an "Error".

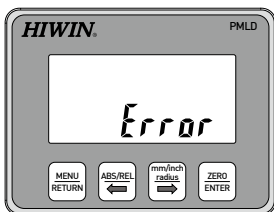

7. Counting direction (Dir)

Function: It is possible to set the direction for incremental signal.

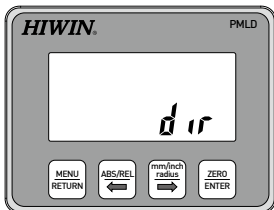

Step 1. Press **MENU RETURN**, then press **ABS/REL** or **mm/inch radius** to enter setting.

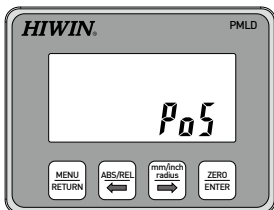



Step 2. Press **ZERO ENTER** to enter setting, than Press **ABS/REL** or **mm/inch radius** to choose counting direction (positive or negative), than press **ZERO ENTER**

8. Resolution setting (Dot)

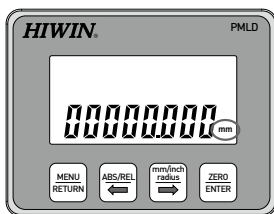

Function: It is possible to set the resolution according to user's requirement.

1. For mm, possible choices are 0.005, 0.01, 0.1, 1mm.
2. For inch, possible choices are 0.0001, 0.001, 0.01, 0.1 inch.
3. For degree, possible choices are 0.001, 0.01, 0.1, 1 degree.



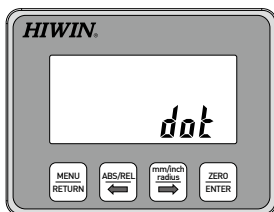

Step 1. Press  to choose the unit needed.

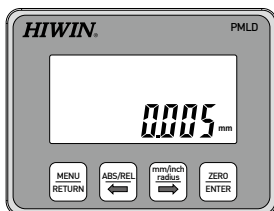

Step 2. Press  once, and press  or  until it shows Dot.



Step 3. Press  to enter setting. Press  to choose the resolution needed.

Finally, press  to confirm.

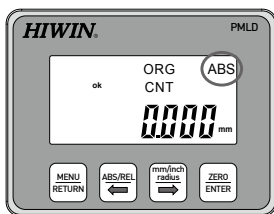

9. Offset setting (offset)

Function: It is possible to set different offsets. But it is only for ABS mode. (PMLD has 5 sets of independent offsets. Offset provides user to switch between different translational coordinates. When using offset, the PMLD adds the according offset value and shows it. So user does not need calculator)



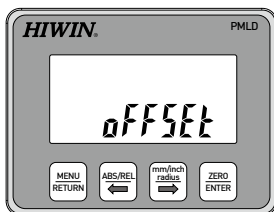

Step 1. Press  to choose ABS mode.



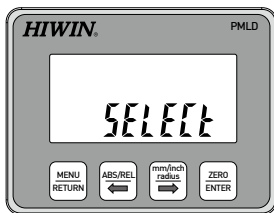



Step 2. Press  once, then press 
or  until it shows Offset.

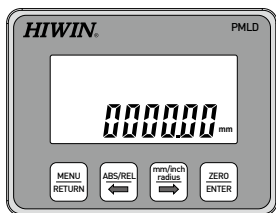

Step 3. Press  or  to select which offset to set. After selection, press 



Step 4. Press  to set the sign. Then press  to switch to next digit. the digit will flicker. Press  to change the value, Press  to confirm.

Note: The setting range is $-360^{\circ} \sim +360^{\circ}$ at the angle mode.

10. Offset calling

Function: After offset value have been set up, user could call the setting value.
This function is only for ABS mode.

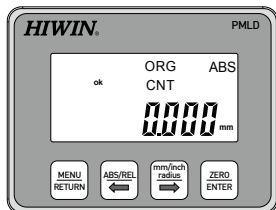



Step 1. Press  to switch into ABS mode.

Then keep pressing on ,

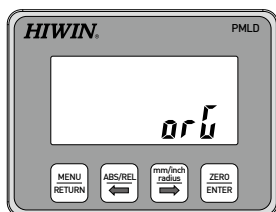
then press  to choose which ORG value to call.



Step 2. After chosen, release  and

 at the same time, panel will show ORG.

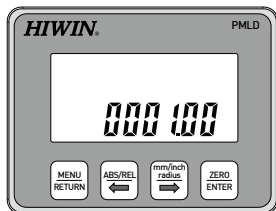





Step 3. Press  will show the preset

value, then Press  again, finish calling process.

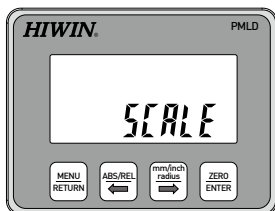



11. Scale (Scale)

Function: It is possible to set to a different scale for coordinate display.

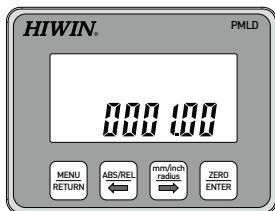

Step 1. Press  once, and press 
or  until it shows Scale. then
press  to enter setting.



Step 2. Press  to change the flashing digit.
Press  to change to next digit.
Press  to change the value. Finally
press  to confirm.

Range: 0.01~1000.00 (Not including 0)

12. Radius setting (Rad)

Function: When the magnetic tape is mounted on a round surface, setting the radius value makes it possible to show the correct angle.

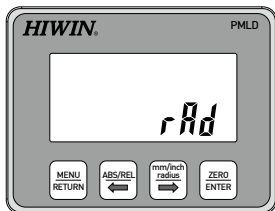

Step 1. Press **MENU/RETURN** once, and press **ABS/REL** or **mm/inch/radius** until it shows Rad. Then press **ZERO/ENTER** to set.

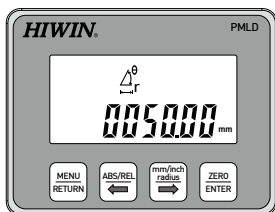





Step 2. The symbol $\triangle \circ r$ means radius. Press **ABS/REL** to change the value, and press **mm/inch/radius** change to next number. The number will be flash. Then press **ABS/REL** to change the value. The unit is only in mm. When finished setting the parameter, press the **ZERO/ENTER** key.

Value : 50-5000mm.

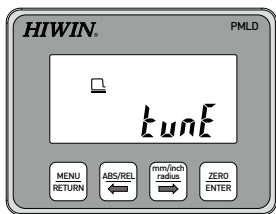
13. Gap Tuning (Tune)

Function: Assists the user to check installation distance between read head and magnetic tape is suitable or not, and correct the sensing signal to improve the system accuracy. After system or read head reinstallation, it is best to do this process again.



Step 1. Press , and next press  or  to select tune. Press to  setting the value.

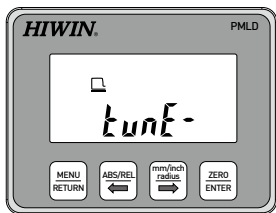

Step 2. The panel display "Tune-" means that it is under detect. Move the read head slowly. The shift should be over 30mm in 10 second.

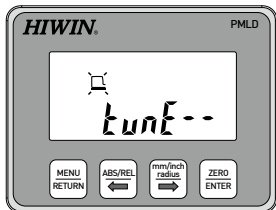

Step 3. The panel display "Tune --" means that it is almost done. The display goes back to normal mode when detect finished and will show the symbol of too large gap, too small gap or suitable gap. The message knows the gap between read head and magnetic tape.

※ This action must be complete in 30 seconds, if 30 seconds passes without completing the system tune, system will jump back to normal mode to reduce the power consumption. This time panel will show , means gap adjustment have not been completed yet.

Note: After completing the gap adjustment movement, you must establish the reference point again.

Tuning Result:

(a) Moderate gap: OK

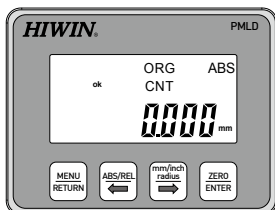

If the detection result demonstrates "OK" symbol, indicated reads and the magnetic tape spacing is moderate.

(b) Too small gap: \updownarrow

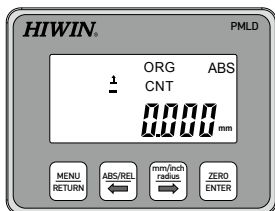

If the detection result demonstrates "⊕" symbol, which indicates gap between read head and magnetic tape is too small after adjustment. You must repeat Tune process again.

(c) Too large gap: \downarrow

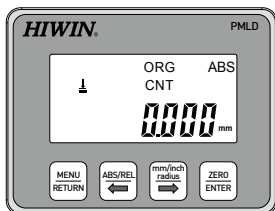

If the detection result demonstrates "⊖" symbol, which indicates gap between read head and magnetic tape is too large after adjustment. You must repeat Tune process again.

(d) Too high surface roughness: $\downarrow \uparrow$

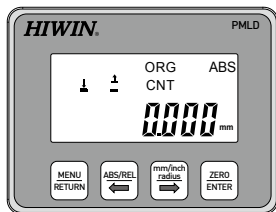

If the detection result demonstrates " $\downarrow \uparrow$ " symbol, which indicates the mounting surface of magnetic stripe is too rough. You must repeat Tune process again after improving the flatness.

Trouble shooting:

(a) Turning Trouble

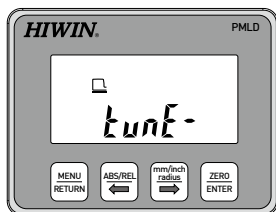

If the panel shows "Tune- or Tune--" for a long time, the gap may be too high or the signal of the read head is unstable. Please press  to finish the detecting process.

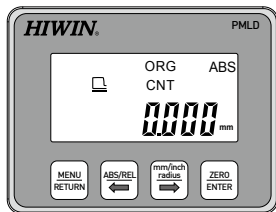

This time the panel shows "" symbol, indicates the gap adjustment is not yet complete. After reducing reads gap, repeat the tune process again, if it still has not been improved, please check the signal of read head works well.

※ After completing the tune process, display could remember related parameters automatically. In this period, if battery has been changed, "" symbol will show on panel. Although it is not affect the system accuracy, it still suggests to do tune process again.

14. Read Head traveling speed setting (Speed)

Function: According to the read head traveling speed requirement, choose the speed limit.

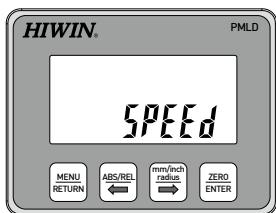

Step 1. Press **MENU RETURN** once, and then press

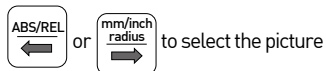

to select the picture

"Speed" then press **ZERO ENTER** to enter menu.

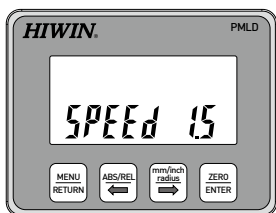

Step 2. Press the **ABS/REL** or **mm/inch radius** key. You can

select the speed limit for read head moving speed. 1.0m/sec, 1.5m/sec, 2.0m/sec, 2.5m/sec, 3.0m/sec. Press **ZERO ENTER**

after setting.

※ The traveling speed upper limit sets bigger, the power consumption becomes larger, thus lowering the battery service life. Lowering the speeds extends the battery service life.

15. Battery capacity (Bat)

Function: Battery current capacity detection

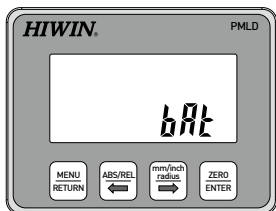

Step 1. Press **MENU RETURN** once, and then press

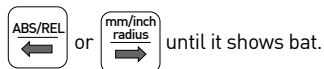

until it shows bat.

Press **ZERO ENTER** to enter the function.

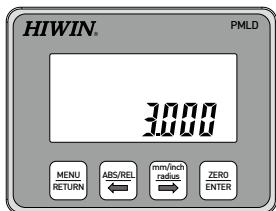





Step 2. The picture will display the value of battery. Press **MENU RETURN** key to go back to normal mode .

※ If the value of the battery is under 2, the display will show "**LOW**" symbol.
Please change the battery.

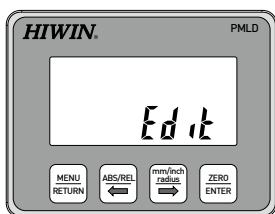
16. Software Version (Edit)

Function: The software version of system



Step 1. Press  once, and press 
or  until it shows edit. press  to enter the function.

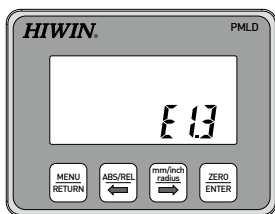

Step 2. The panel will show current software version. Press  once, and go back to normal mode.

17. System default parameter





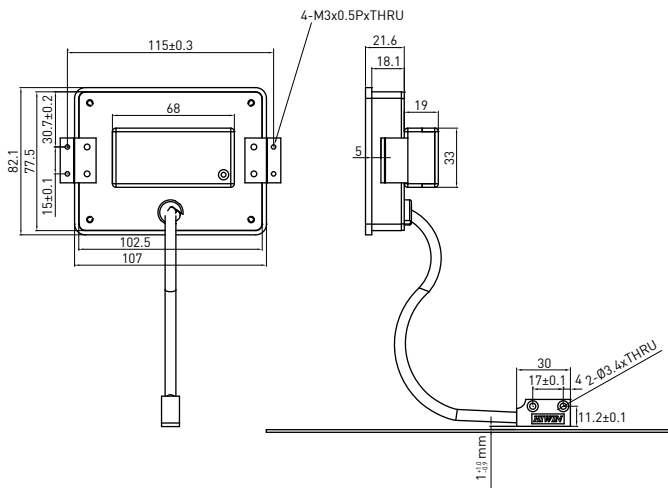













Function	Description	Default
Dot	Resolution	(1) 0.005mm (2) 0.0001inch (3) 0.001
Dir	Direction	Pos
Org	Origin	0
Offset	Origin offset	0
Scale	Scale	1.00
Rad	Radius	50mm
Speed	Speed limit	1.5m/sec



















18. Dimension :



19. Appendix

(1) Panel display and function antithesis:

Name	LCD Display	Name	LCD Display	Name	LCD Display
0		1		2	
Name	LCD Display	Name	LCD Display	Name	LCD Display
3		4		5	
Name	LCD Display	Name	LCD Display	Name	LCD Display
6		7		8	
Name	LCD Display	Name	LCD Display	Name	LCD Display
9		A		B	
Name	LCD Display	Name	LCD Display	Name	LCD Display
C		D		E	
Name	LCD Display	Name	LCD Display	Name	LCD Display
F		G		H	

Name	LCD Display	Name	LCD Display	Name	LCD Display
I		J		K	
Name	LCD Display	Name	LCD Display	Name	LCD Display
L		M		N	
Name	LCD Display	Name	LCD Display	Name	LCD Display
O		P		Q	
Name	LCD Display	Name	LCD Display	Name	LCD Display
R		S		T	
Name	LCD Display	Name	LCD Display	Name	LCD Display
U		V		W	
Name	LCD Display	Name	LCD Display	Name	LCD Display
X		Y		Z	

(2) Technical description :

(a) Absolution mode:

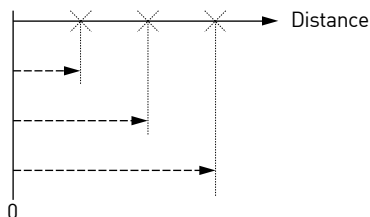

The same origin, you can not change the origin position.

(b) Relation mode:

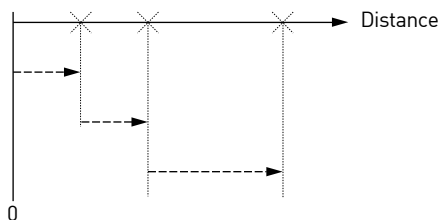

You can change any origin by your demand.

(c) ORG (ORG0、ORG1、ORG2、ORG3、ORG4) description:

In the woodworking machine application, it does not cuts the same length by user discretion. [Example: 1 meter and 2 meters, following under description]

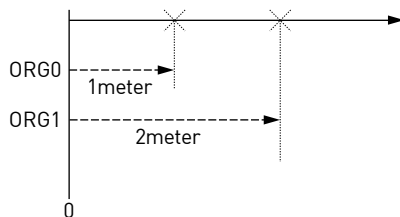

The user only changes the setting of the origin. (You need 1 meter that sets ORG0 for 1 meter origin, and for 2 meters, set ORG1 for 2 meter origin.) This function can increase the efficiency in measurement above 2 sizes.

(d) CNT (CNT0、CNT1、CNT2、CNT3、CNT4) description:

In the woodworking machine application, it cuts not the same length on same wood. (Example: 30 centimeters and 40 centimeters, following under description)

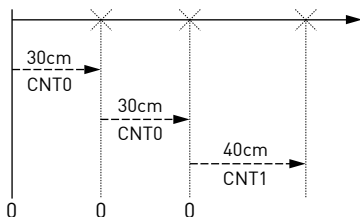

The user only changes the CNT setting. User can direct the read out the position and cuts the wood. They don't need to set the parameter once again.

(e) Origin compensation:

You cannot change the position of origin in absolute mode. If you need to change the position of origin, you must use the origin compensation to offset the position of origin.

20. Version history

version	Description of change	By	Date
V1.0	First edition	Wei	10.Mar.2008
V1.1	Correct the dimension picture description (P.25) and content wrong (P.10)	CWLin	30.Dec.2010